



Red River Valley
**Home & Garden
Show**

February 24 - 26, 2012 • FARGODOME

Exhibitor's Packet
#1

Education Opportunity
"Make your booth a success!"
Tuesday, Jan. 24
See pg 23 for more details

If you **ARE NOT** the contact for the
Red River Valley Home & Garden Show,
please pass this packet on **IMMEDIATELY** to the
correct contact.

Electronic forms can be found at www.hbafm.com/exhibitor.

Thank you!



Important Deadlines

All forms are enclosed. If you need additional forms, visit www.hbafm.com/exhibitor.
If you will be needing hotel reservations - make them soon!

Jan. 20

Show Guide Deadline - last day to purchase ad(s) in the show guide or for changes with The Forum.

- Remember to double check your **new booth # on pages 12-13**. Also, check your company name, phone number, buyer's guide category and location on pages 14-17. It will appear as listed unless we hear from you.

Feb. 3

Name Badge Request Deadline
(ONLINE at www.hbafm.com/exhibitor)

Any request(s) received after Feb. 3 are not guaranteed to be delivered before show set-up days.

- Remember, **exhibitors MUST WEAR badges to enter the show!**
Exhibitor entrance is on the West side of the Fargodome.

Feb. 3

***Exhibitor Discount Tickets Deadline** - Return forms to the HBA office. Forms must be received by this date in order to ensure exhibitors time for distribution. Customers must have ticket in hand for entrance to the show.
No Will Call.

Feb. 15

***Electrical Contract Deadline - Return to FARGODOME.**

This includes any electrical, water, phone cable TV or internet needs. Special requests are required 30 days prior.

After Feb. 15, floor rate will be charged.

Payment is required with contracts. Mail to Fargodome - DO NOT FAX.
Fargodome: Attn. Utility Order Form 1800 University Dr. N. Fargo, ND 58103

Feb. 15

***Decorator Contract Deadline - Return to United Rentals.**

United Rentals: 4242 Main Ave. Fargo, ND 58103

This includes table skirting, tables, chairs, audio visual, exhibit space carpet or flooring. **After Feb. 15, floor rate will be charged.**

****Forms available for download at www.hbafm.com/exhibitor.***

Table of Contents

Schedule of events 4

Event information

- Exhibitor registration & entrance 5
- ***Exhibitor name badges ONLINE ONLY!**..... 5
- Parking & parking passes 5
- ***Exhibitor discount tickets (form enclosed)**..... 6
- Exhibitor storage 6
- Exhibitor lounge 6
- N.D. special event sales tax 6
- Show office..... 6

Booth construction

- Standard configuration 7
- Floor tape 7
- ***Electrical needs (form enclosed)** 7
- ***Decorator needs: tables, chairs, skirting, etc. (form enclosed)**..... 7
- Fire Marshal Requirements (grills and LP tanks)..... 7, 22
- Hanging signs & balloons 8
- Food (selling and giveaway) 8

Move-in 9-10

Hotel/motel accommodations 10

Move-out 11

Final Packet 11, 24

Exhibitor list and map - please verify **NEW** booth numbers and location 12-13

Buyer’s guide - please verify name, phone number and category 14-17

Advertising rate sheet for OFFICIAL Show Guide 18

Seminar schedule 19

Market your company the right way! Tips for before, during and after the show 20-21

Education opportunity - “Make Your Booth a Success!” 23

Sponsors and sponsorship opportunities..... 24

*Forms available for download at www.hbafm.com/exhibitor.

If you have questions concerning information in this packet please refer to the Standard Terms and Rules & Regulations included with your contract or call the HBA at (701) 232-5846.

If you are showcasing a new technology, innovation or unique item in your exhibit, please contact the HBA office. This information is helpful in promoting the show.

2012 Schedule of Events

Wednesday, Feb. 22

7:30 a.m..... Move-in begins for bulk space (Triple and larger exhibitors ONLY!).

- All drive-ins must be on Wednesday.
- Forklift available for limited time: 6 a.m. - 5 p.m.
- You must have a scheduled dock time and present a move-in pass to enter field level staging area.
- Please arrive a few minutes ahead of your dock time, just in case your vehicle needs to be spray-washed.

11 p.m..... Building closes.

Thursday, Feb. 23

7:30 a.m..... Move-in begins for the remainder of the field level and the concourse is now open for set-up.

- You must have a scheduled dock time and present a move-in pass to enter field level staging area.
- Forklift available for limited time: Noon - 5 p.m.
- Exhibitors located on the West wall of the field level may move in after 4 p.m.

11 p.m..... Building closes.

Friday, Feb. 24

7:30 a.m..... Dock and overhead door will be available until 10 a.m. with special permission only.

NOON..... Exhibit clean-up. Move-in concluded.

2 p.m..... Exhibitors' doors open. Remember to allow enough time to park so exhibits may be staffed by 2:30 p.m. Only the **West entrance** will be open for exhibitors. Please park at the back of the parking lot to reserve parking for consumers.

2:30 p.m..... Exhibitors should be in the building and booths staffed.

3 p.m..... Show opens.

9 p.m..... Show closes.

Saturday, Feb. 25

8 a.m..... Exhibitors' doors open: **West side only!**

8:30 a.m..... Exhibitors should be in the building and booths staffed.

9 a.m..... Show opens.

6 p.m..... Show closes.

Sunday, Feb. 26

10 a.m..... Exhibitors' doors open. **West side only!**

10:30 a.m..... Exhibitors should be in the building and booths staffed.

11 a.m..... Show opens.

5 p.m..... Show closes. Do not begin to pack exhibits until show is closed. Move-out begins after show closes.

- Single- and double-booth exhibitors requiring use of the overhead door/dock must disassemble and pack booths before acquiring a move-out pass.
- Triple and larger exhibitors must disassemble and pack booths. Please make sure you have received your move-out pass by this evening for Monday's dock times. Booths must be packed up Sunday night.
- Forklifts will be available: 5 - 9 p.m.

11 p.m..... Building closes.

Monday, Feb. 27

7 a.m..... Building opens. Move-out for bulk space begins.

- Forklift available for limited time: 7 - 11 a.m.

3 p.m..... Building closes.

Event Information

Exhibitor Registration & Entrance

Exhibitor registration:

- Exhibitor registration area will be set-up Wednesday, Thursday, and Friday morning on the field level in the northwest corner of the Fargodome.
- Fargodome and Home & Garden Show staff will be available for late electrical needs and late sign-ups.

****Please remember to pick up name badges if applicable at this time.****

Exhibitor entrance:

- **During move-in**, doors will be open on the east, south and west sides of the Fargodome.
- **During the show**, the exhibitor entrance is on the **WEST SIDE** of the Fargodome (bank of doors south of ticket lobby). Exhibitors will not be allowed to enter through any other doors and **MUST** wear a Home & Garden Show name badge to enter. Exhibitors not wearing a badge must pay the \$8 admission price. The Convention & Visitors Bureau will be there answering questions. A name badge can be typed up by the CVB at the west entrance.
- For parking information see "Parking & Parking Passes" below.

Note: Once the show has begun, exhibitors must enter on west side of Fargodome and wear a Home & Garden Show name badge to enter. If not wearing this name badge, you will be charged the \$8 admission fee.

NO EXCEPTIONS!

Exhibitor Name Badges ****ONLINE ONLY!****

- Fill out form at www.hbafm.com/exhibitor
- Due Feb. 3

Be sure to enter each person's name (both first and last name). The number of badges allocated to your exhibit size is listed on the online form. Additional badges may be purchased for a fee. If the names are entered by the deadline, the company contact may receive the badges in the mail before show set-up. Please remember to hand them out to the appropriate people prior to move-in. These badges will be their ticket into the show.

Please do not lose them OR leave them in your booth!

Parking & Parking Passes

****Please remember, you may park in front of the doors only to drop off.****

Once your vehicle is empty, please remove it. **DO NOT** leave your vehicle unattended. Keep in mind, if you are parked illegally, the Fargodome may have your vehicle towed.

Parking:

- **During move-in**, there is no charge for parking. You may park in the lots where the following entrances will be open:
 - East Side Lobby
 - South Side
 - West Side
- **During the show**, designated parking for exhibitors with trailers or semis will be lot "E," while Lot "F" is designated for car and pickup parking. Please refer to the map on page 8 for designated areas.
- **Parking access during the show** for exhibitors is available from either 19th Ave. (down Albrecht Dr.) or 17th Ave. (For information on exhibitor entrances during the show see "Exhibitor Registration & Entrance" section above.)

Parking Passes:

- Each exhibitor will receive at least one weekend parking pass (number of passes depends on size of exhibit) from the HBA in the final exhibitors packet.
- **During move-in only**, weekend parking passes will be available from the Fargodome at a cost of \$12 each. This is a three-day pass that allows you to come and go as you please. Without a weekend pass, parking is \$3 each time you park.

Event info con't from previous page

Exhibitor Discount Tickets

Exhibitor discount tickets must be ordered on the enclosed form by Feb. 3. Forms received after this date have NO GUARANTEE they will be sent in time for you to distribute to consumers. Consumers must have complimentary tickets in hand for entrance to the show.

- Send the form to the HBA office, 1802 32nd Ave. S., Fargo, ND 58103, email kirsten@hbafm.com or fax (701) 280-1108.

Exhibitor Storage

There is **absolutely no storage** available at the Fargodome. Exhibitors are responsible for reserving storage space and may do so through the designated show decorator, United Rentals at (701) 293-9225. The Fargodome will not accept deliveries prior to the exhibitor's arrival.

Exhibitor Lounge

The **Exhibitor Lounge** is located in the Fargodome meeting rooms F101 and F102 on the field level near the escalators. Keep in mind, the Fargodome is a non-smoking building. **This policy is strictly enforced.**

- Food, snacks and beverages will be available to all exhibitors starting half an hour before the show opens each day and will be open until half an hour before the show closes each day.
- IdeaOne Telecom is the Exhibitor Lounge Sponsor.
- Culligan Water Conditioning is the Beverage Sponsor. Check them out in booth #495.

N.D. Special Event Sales Tax

If Applicable: All exhibitors not holding North Dakota Sales Tax permits must return a Special Event Sales Tax Return within 15 days of sales activity. This form should not be used by anyone holding an active North Dakota sales and use permit. A list of all Home & Garden Show vendors will be mailed to the office of the State Tax Commissioner at the end of the show. Remember to include county, state and city sales tax when making product sales.

Show Office

Show Office:

- The show office will be located in room F237 on the field in the northwest corner, behind the registration area.

Booth Construction

Standard Configuration

The standard booth configuration is 10 ft. square and multiples thereof. Displays may not exceed 10 ft. in height across the back of the booth including signs and no more than 3 ft. in height half the distance from the aisle to the back curtain.

Variations from this configuration must be approved in advance of set-up by the Home & Garden Show staff. During set up, measure booth from front towards back of allotted area to allow for Fargodome electrical equipment to be placed between back-to-back exhibits.

- EXHIBITS MUST BE FINISHED ON THE BACKSIDE.
- CARPET CAN NOT EXTEND INTO THE AISLE.
- Concourse/Lobby booths: 8' x 10' (D x W)
- Field level booths: 10' x 10' (D x W)

****For design/configuration questions, refer to the rules and regulations in your contract or call Bryce Johnson at (701) 232-5846.****

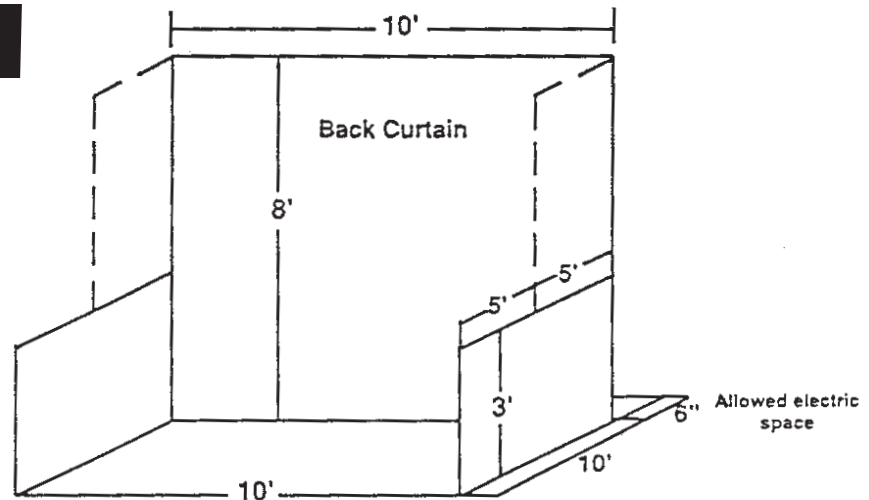

****Measure booth from front to back when setting up!****

Floor Tape

Wrestling mat tape is the only tape allowed, there are no exceptions. Tape is available through the decorator, United Rentals, and the Fargodome. Prices and sizes of rolls of tape may vary. Exhibits using unauthorized tape or demo materials will be assessed a fine by the Fargodome for restoration/cleanup of \$100/ft.

Electrical Needs

Additional lighting is recommended for exhibitors to ensure your exhibit is properly illuminated. Additional lighting and all other **normal** electrical needs must be ordered on the enclosed form by 5 p.m. Feb. 15 to receive the advance rate.

- **Special requirements:** If you are in need of special requirements, contracts must be sent to the Fargodome 30 days prior to the show.

****CONTRACTS MUST BE MAILED TO THE FARGODOME WITH PAYMENT. DO NOT FAX.****

Decorator Needs

If you are in need of any of the following items: tables, chairs, skirting, carpeting, DVD, TV, internet, etc. **send the enclosed decorator contract to United Rentals, by 5 p.m. Feb. 15.**

Lower rates on electrical and decorator orders, if contracted by 5 p.m. Feb. 15!

Fire Marshal Requirements

Flammable materials: All materials used in the exhibit hall MUST be nonflammable to conform to the fire regulations of the Fargo Fire Department. Open flames are not permitted at any time in your exhibit space.

- No combustible decorations (crepe paper, tissue paper, cardboard, corrugated paper, hay or straw bales) shall be used at any time. All packing paper, excelsior and wrapping papers are to be removed from the floor and must not be stored under the tables or behind displays. All muslin, velvet, or any cloth decorations must stand a flame proof test as prescribed by the Fargo Fire Department regulations.
- All vehicles or items with gas tanks must have them taped shut. If your exhibit contains any petroleum-based products, i.e. gasoline, the following guidelines must be met: (1) the gas tanks must be less than 1/3 full of fuel, (2) the gas tanks must be taped shut, and (3) the battery terminals must be disconnected.

****Material not conforming with such regulations will be removed immediately at the Exhibitor's expense.****

More Fire Marshal requirements can be found on page 22.

Booth construction con't from previous page

Hanging Signs & Balloons

No signs, apparatus, etc., (i.e. balloons, blimps or other remote controlled devices) will be permitted to extend more than 10 ft. above the floor in anything less than a 20' x 20' booth (400 sq. ft.), and no interference with light or space of other exhibitors will be allowed. No aerials are allowed on singles, doubles or triples.

Hanging signs:

- Signs may not be hung from the ceiling, beams or columns without approval of the Show and Fargodome management. Any displayed banners or posters must be fitted with grommets and hung with rope or string. Banners or posters cannot be hung using tape. Call Bernie with the Fargodome at (701) 298-2639 for information on hanging signs. For other details, please see Section C on your contract under Rules & Regulations.

Balloons:

- Balloons must be tethered. No helium or lighter-than-air balloons allowed unless they are tethered, display/aerial balloons in an appropriate-sized booth (see above). A deposit must be left with the Fargodome prior to set up and display of such items.

Distribution of Food

Selling food:

- No food may be sold without prior approval from the Food & Beverage Manager of the Fargodome. All vendors who wish to sell food items must pay a fee of \$200 or 30 percent of gross sales after tax, whichever is higher. All vendors must contact Fargodome Food & Beverage Services at (701) 298-2651 for approval.

Food giveaway:

- Any food or beverage given away at your booth **MUST** be a sample size (i.e. coffee/water in a 4 oz. cup/bottle or candy in a 4 oz. bag). **Absolutely no popcorn, peanuts, or nuts in shells.** All vendors must contact the Fargodome Food & Beverage Services at (701) 298-2651 for approval.

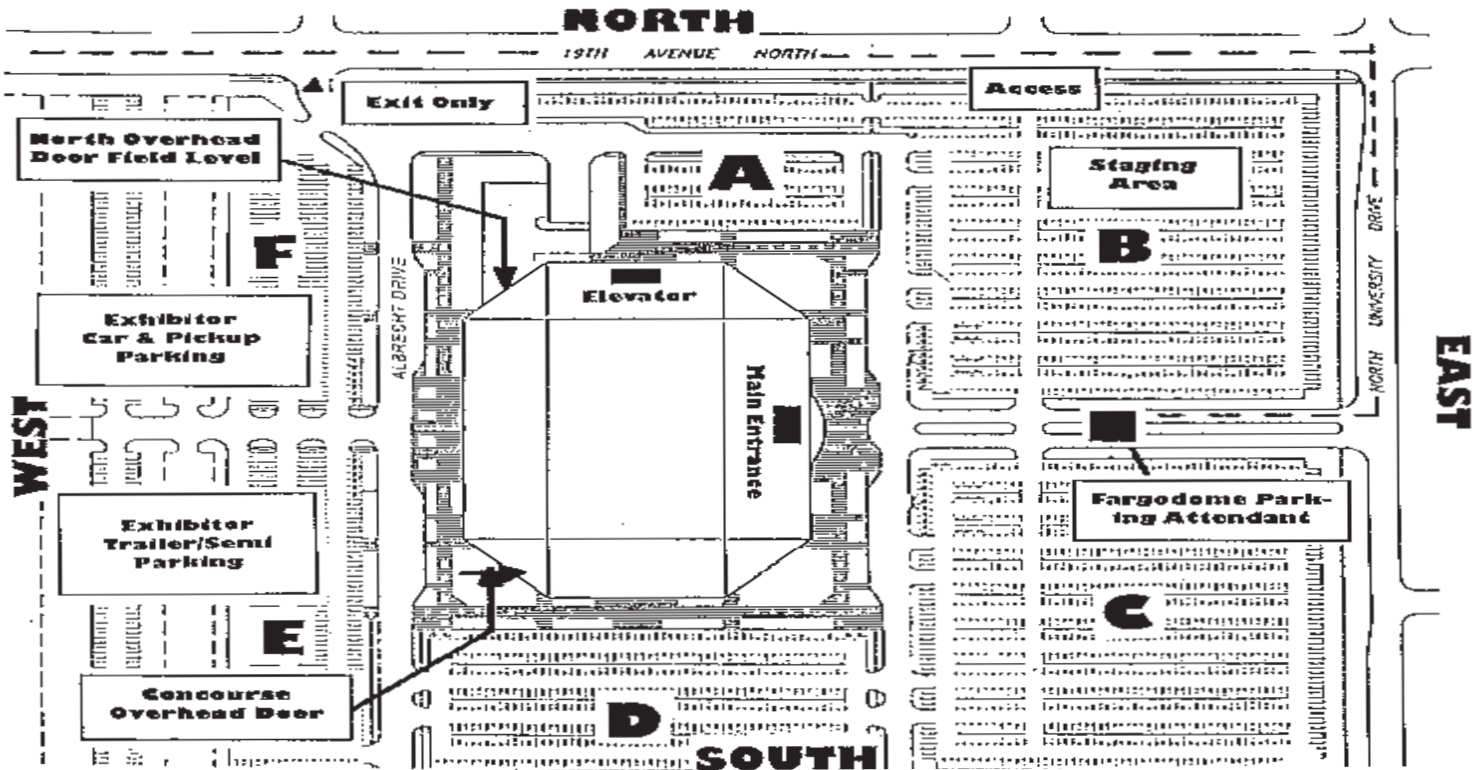

Move-In:

ONLY east, south and west doors will be open.

During Show:

ONLY west doors are open for exhibitors!

Move-In

Wednesday, Feb. 22 from 7:30 a.m. - 11 p.m.

Drive-ins ONLY!

Three booths or larger only during this time.
Move-in times MUST be confirmed prior, if using overhead door or loading dock.

Thursday, Feb. 23 from 7:30 a.m. - 11 p.m.

No Drive-ins!

Singles, doubles and concourse exhibitors.

Friday, Feb. 24 from 7:30 a.m. - 10 a.m.

Prior permission only!

Overhead door and dock area will be open until 10 a.m. with special permission.
Show clean-up noon - 2 p.m. Show opens at 3 p.m.

*****Forklifts will be available on a limited basis.*****
Look for move-in passes in your final packet, if requested.

Elevator & Carts

Elevator:

- The freight elevator is located on the northwest end of the Fargodome.

Carts:

- Carts will be available Wednesday and Thursday for field, concourse and lobby exhibitors. Please be considerate of your fellow exhibitors by unloading and returning carts immediately to dock area after use. Do not keep the cart while you are setting up your booth.

Field Level Booths

Exhibitors who have materials that can be carried in will have access on three sides of the Fargodome: east, south and west. (For parking and exhibitor entrance questions see page 5.)

Overhead Door & Dock Usage: *(located in northwest corner of field level)*

****You MUST have a move-in time and pass to utilize the overhead area.****

- Contact Bryce at (701) 232-5846 to schedule a move-in time.
- Overhead door dimensions are 13'6"H x 27'7"W.
- Do not plan on fitting in between slow times to use the overhead door.
- **Move-in / dock passes** will be sent out as requested and must be displayed in the windshield at time of move-in. Each pass represents ONE truck and ONE time. Exhibitors with multiple trucks must have the same number of passes to match. Multiple trucks may want to stagger dock times if it's appropriate. If you receive your pass(es) and there are not enough, please call the HBA office at (701) 232-5846.
- Please arrive 10-15 minutes earlier than your move-in time. If you are late, your move-in time will be forfeited!
- **Those with THREE OR MORE BOOTHS** may move in Wednesday, Feb. 22.
- **Double OR single booths** may move in Thursday, Feb. 23.
- **Access:** Anyone using the overhead door area must access it from University Dr. (see map on previous page). **The 19th Ave. access will be used as an EXIT ONLY area!**
- A parking attendant will direct exhibitors with move-in passes to Lot "B" and line them up according to move-in times.

Move-in con't from previous page

It is important to stay within your allotted time and ensure you have sufficient manpower to facilitate a swift unload. It will benefit you and your fellow exhibitors. The Home & Garden Show and Fargodome management want to make the move-in as organized and stress-free as possible which requires your cooperation. Thank you!

- If it snows or conditions are wet, all vehicles driving in on Wednesday will be spray-washed by Fargodome employees before entering the field.

Friendly Reminder: Please be considerate during your scheduled move-in time. Your dock time is for loading and unloading **ONLY!** It does not entitle you to leave your vehicle inside the building. Drive in, unload your materials onto carts and bring to your booth area. Please return carts as soon as possible and **DO NOT** leave your vehicle inside the building while setting up your booth.

Concourse & Lobby Booths

Concourse and lobby move-in is on Thursday, Feb. 23. **NO DRIVE-INS ALLOWED | Unloading in overhead area ONLY.**

Booth placement:

- Please remember to set up your booth starting at the front of your allotted booth space.
- Booth size: 8' x 10' (D x W)

Overhead door:

- **Concourse**
 - Overhead door on concourse is located in the southwest corner and is used for **UNLOADING ONLY!**
 - Dimensions are 9'11"H x 10'6"W.
 - Anyone needing use of the overhead door may sign-up for a time by calling the HBA office at (701) 232-5846.
- **Lobby**
 - Dimensions are 11'6"H x 10'W.

Hotel / Motel Accommodations

Out of town exhibitors needing to make hotel reservations can try one of the following:

AmericInn: (218) 287-7100 | 600 30th Ave. S., Moorhead

Candlewood Suites: NEAR FARGODOME | (701) 281-4900 | 1831 NDSU Research Dr., Fargo

Days Inn and Suites: NEAR FARGODOME | (701) 281-0000 | 1507 19th Ave. N., Fargo

Holiday Inn: NEAR WEST ACRES MALL | (701) 232-0000 | I-29 & 13th Ave. S., Fargo

Homewood Suites by Hilton: NEAR FARGODOME | (701) 235-3150 | 2021 16th St. N., Fargo

Microtel Inn & Suites: NEAR FARGODOME | (701) 281-2109 | 1101 38th St. N., Fargo

Radisson Hotel of Fargo: DOWNTOWN FARGO | (701) 232-7363 | 201 5th St. N., Fargo

Reserve rooms now! Hotel occupancy is filling quickly because of a youth hockey tournament in town!

For complete list of further accommodations in the Fargo-Moorhead area, contact the Fargo-Moorhead Convention & Visitors Bureau at (800) 235-7654 or visit www.fargomoorhead.org.

Move-Out

Move-out commences **AFTER THE SHOW CLOSES at 5 p.m.**, and not before. Packing your booth prior to 5 p.m. gives the consumer the impression the show is closed. It is also dangerous! Carts will not be available until closing announcements have been made. Carts cannot be held.

Any or all booths where materials are movable without the aid of the field level overhead door or dock shall begin packing up and moving out **IMMEDIATELY** after the show closes at 5 p.m. Sunday, Feb. 26. The Fargodome will be open until 11 p.m. The concourse overhead door will be available all evening.

Field Level Booths

****DO NOT** move any part(s) of your display to the overhead door area until you have been given clearance by the Fargodome staff working in the overhead door area.**

Singles & Doubles:

- May start take-down immediately after the show closes at 5 p.m. Sunday, Feb. 26.
- **Overhead door usage:** Your booth **MUST BE PACKED** before the Fargodome will issue a move-out pass (passes can be picked up in the registration area in the northwest corner of the field level). Exhibitors in the first quadrant closest to the overhead door area who are not bulk exhibits will move out first. **DO NOT** move any part(s) of your display to the overhead door area until you have been given clearance by the Fargodome. All bulk exhibits must move out Monday. Please see “Triples & Larger” below for more info.
- After receiving your pass, you will be lined up by Fargodome staff in numerical order. Information will be handed out prior to closing on Sunday, Feb. 26.
- Only exhibitors with single and/or double booths will be allowed to use the overhead door area on Sunday evening.
- FORKLIFTS WILL BE AVAILABLE 5 - 9 p.m.

Triples & Larger:

- **Overhead door usage** will be scheduled for move-out Monday, Feb. 27. Your booth(s) must be disassembled and packed on Sunday night!
- **YOU MUST HAVE A MOVE-OUT PASS TO USE THE OVERHEAD DOOR OR DOCK ON THE FIELD LEVEL.** Move-out passes will be handed out at the show, but must be scheduled ahead of time with Bryce: (701) 232-5846. This move-out time is when you can use the overhead door, so you should be packed and ready to go at this time!
- LIMITED FORKLIFTS AVAILABLE MONDAY 7 - 11 a.m.

Concourse & Lobby Booths

- May start take-down immediately after show closes at 5 p.m. Sunday, Feb. 26.
- **Overhead door usage is first-come-first-serve.**

What's coming in your FINAL PACKET:

1. **NAME BADGES:** If ordered and requested by Feb. 3. ONLINE FORM at www.hbafm.com/exhibitor.
2. **WEEKEND PARKING PASS:** (value \$12) compliments of the HBA! The number of passes included will depend on size of exhibit! **DO NOT LOSE THESE. THEY WILL NOT BE REPLACED.** More info on parking passes on page 5.
3. **MOVE-IN PASS(ES):** If you scheduled a move-in or drive-in time with Bryce at (701) 232-5846.
4. **EXHIBITOR DISCOUNT TICKETS:** If ordered by Feb. 3. Available for \$6 each. (Regular ticket price is \$8.)

Exhibitor List

(As of Jan. 9, 2012)

Display Name	Booth #	Display Name	Booth #	Display Name	Booth #
A & T Landscaping	C343	Edgewood Village	530	Laney's, Inc.	1240
A Sound Environment	180	Edward Jones Investments	C541	Lemke Home Improvements, Inc.	C195
ABC Seamless	C330, 1060	Electro Watchman, Inc.	905	Life Chiropractic Center	C114
Absolute Landscaping	650	Encore Home Improvements	C300	Lindsay Ecowater Systems	C550
Accent Kitchen & Bath	175	Enercept SIPs	1205	Lumber Liquidators	660
ACME TOOLS	800	Energy Balance System	C415	Luxury Bath of Fargo	110
All Finish Concrete	505	Environmental Air Solutions	L11	M & E Sales	C370, C365
Amcon Block & Precast	487	Exclusive Home Products LLC	C115	Mark Enterprises, Inc.	1200
American Custom Decks	C304	Executive Mortgage	C540	Marvin Windows & Doors	1140
American Family Insurance	825	Extreme Panel Technologies, Inc.	C240	Mayville Portland EDC	735
American Federal Bank	285	EZ Open Garage Door, Inc.	1285	Merry Maids	C440
Anderson Hardwood Floors LLC	1275	F. M. Water Systems, LLC - Kineticco	410	Midnight Solutions Technologies	C203
Anderson Homes, Inc.	460	Fabricators Supply	970	Midwest Fasteners	C150
Antenna Logic	C197	Fabricators Unlimited	980	Midwest Grinding, Inc.	767
Arctic Audio, Inc.	C191	Facelift Kitchen and Bath	C161, C163	Mill Creek Custom Cabinetry	1075
Arista Realty / Horizon Shores	C110	Fargo Glass & Paint Company	850	Minnesota State Community and Technical College	145
Backyard Adventures	352	Fargo Imports	C270	Minnesota Warehouse Furniture & Amish Gifts	C210
Baker Garden & Gift	215	Fargo Tractor	950	Minnkota Windows	1010
Barnesville Economic Development Authority	575	Ferguson Bath, Kitchen, & Lighting Showroom	685	Monkey Bars Garage Storage	C515
Barnesville Homes Inc.	C316	First Class Mortgage	627	Morton Buildings	C340
Basement Technologies of ND, Inc.	715	First International Bank & Trust	C130	My Pillow, Inc.	769
B-Dirt Construction, LLC	470	First Mortgage Service	646	NAI North Central	1065
Bergeson Nursery	C470	Flags West / Pink Ink	630	Nectar of the Vine	1097
Bernie's Water Conditioning	179	FM Home & Patio	620	Nelson Window Company	250
BFJ Home Builders Inc.	430	Foltz Buildings	636	New Century Press	C545
Blue Ox Timber Frames, Ltd.	C434	Gate City Bank	405	NEWMAN Fence	885
Boulder Creek Custom Homes, LLC	412	Grace Electric	C456	Nichols Family Chiropractic	C485
Braaten Cabinets Inc.	615	Granite Transformations	1195	Nodak Stores	240
Bremer Bank	1260	Great Plains Brokerage / Sanford Health Plan	900	Nor-Son, Inc.	930
Budget Blinds of Fargo	1110	Greenscape Companies Inc.	125	North Central Geothermal	L5
Building Concepts, Inc.	515	Gutter Topper of ND, Inc.	787	North Dakota One Call	400
CAMBRIA	C303	Hankinson Community Development Corporation, Inc.	C344	Northern Turf Management, Inc.	210
Carpet Mill Club	625	Hanlon Construction	C460	Northland Truss Systems, Inc.	570
Cass County Electric Cooperative	780	Harmonious Architecture	L7	Norwex Enviro Products	C275
Cass County Soil Conservation District	C320	Hazelwood Flagpoles	L47	Oasis Landscapes	297
Chase Realty	865	Healing Arts Chiropractic	C311	Official Massage Pillow	C267
Chris Hawley, Architect	887	Hebron Brick Supply	C290	Olson Awning & Canvas	600
City of Dilworth	C503	Heritage Homes	960	Olson Pools & Spas	220
City of Fargo - Forestry Department	C420	High Plains Water	1000	Opp Construction / Patio World	1050
City of Fargo - Recycling Services	C410	HighPoint Homes	C430	Outdoor Design & Living Guide	C295
City of Frazee	C495	Hillsboro EDC	1070	Overhead Door Co. of Fargo	C373
City of Kindred	C561	Homark Homes Inc.	C487	Pacific Sound and Video	420
Coatings Unlimited	C200	Home & Hearth	1095	Park Co. Realtors	720
Coldwell Banker First Realty	645	Home Depot	1190	Partylite Gifts	C500
Comfort World Windows	795	Home Geothermal Systems	995	Paul Bunyan Tree Service	790
Crane Johnson Lumber	595	Home Heating, Plumbing	895	Paula Rae Homes	C563
Cry of the Loon Art Gallery	L40	Hot Springs Spas & Pool Tables 2	L50	Pella Windows & Doors	640
Culligan Water Conditioning	495	In The Shades	L67	Prairie Restorations, Inc.	C324
Curb Design	200	Innovative Basement Systems	1100	Prairie Supply, Inc.	C351
Curb Xtrem	C465	Innovative Stone Design, LLC	765	Prairie Windows	490
Custom Aire's One Hour Heating & Air Conditioning	835	InSealation Solutions LLC	L13	Precision Concrete Cutters, Inc.	320
Cutco Cutlery	C366	Interior Affairs	450	Precision Plumbing, Electric, Heating & Cooling	C310
D & M Industries	1250	Interstate Spray Foam	L60	Premium Decks	675
D & M Roofing Company	C280	Invisible Fence of Fargo	C555	Price-Rite Home Improvements, Inc.	235
Dakota Fence	120	Jack Chivers Realty	935	Property Resources Group	380
Dakota Kitchen & Bath	665	JD's Salsa in Seconds	L96, C336	Prudential Premier Real Estate	680
Dakota Wall Systems, Inc.	690	Jordahl Custom Homes, Inc.	1045	Quality Cabinets, Inc.	C246
DECKMASTERS	100, 300	JR Construction	C520	Quality Concrete, Inc.	363
Design Direction	C565	Kensok's Hardwood Floors, Inc.	920	Rainbow Play Systems	255
Design One Homes, LLC	C507	Kitchen Solvers of Fargo	760	RE/MAX Realty 1	590
Digital Media Plus, Inc.	493	Knoke Seamless Siding and Gutters	L1	Real Deals on Home Decor	C202
DIY Wood Studio	L92	Kochmann Brothers Homes, Inc.	1187	Red River Glazing, Inc.	915
DogWatch Hidden Fence / Elite Outdoor Lighting	C165	Lake Agassiz Habitat For Humanity	C314	Reliable Energy Solutions, Inc.	C450
Drain Services, Inc.	520	Lake Region Electric Cooperative	1175	Rigels, Inc.	820
Dust Busters Furnance & Duct Cleaning, Inc.	C265	Lakes Specialty Services	C313	Robert Gibb & Sons	245
Earthloop of Fosston	510	Lakeland Log & Timberframe	C497	Ron Holstrom Antique Floors & More	880
		Lamperts Yards, Inc.	740	Rose Creek Design	C205

Exhibitor list con't on next page

Exhibitor list con't from previous page

Display Name	Booth #	Display Name	Booth #	Display Name	Booth #
Royal Prestige	C480	State Bank & Trust	C100	Town & Country Credit Union	C341
Rusco Window & Cabinets	990	Steam Masters Carpet Care	1090	Town & Country Realty LLC	775
Ryan's Rustic Railings & Furniture, Inc.	L80	Steamatic of the Red River Valley	473	Tubs of Fun!	1055
Sanford HealthCare Accessories	C435	Stone Countertop Outlet	1235	Turtle Shell Stained Glass Studio	1170
Scentsy	C224	Structural Materials, Inc.	455	Twin City Garage Door	655
Sculpture by Design	485	Studs to Rugs, Inc.	770	Twin City Sharpening, Inc.	890
Security Solutions - Powered by ACS	C535	Sun Companies	C204, C215	US Bank	C526
Sensible Security	C334	Superior Steam Cleaning & Restoration	975	Valley Central Vacuum	695
Shaklee	C121	Swenson Masonry LLC	993	Valley Lights	278
Signature Landscapes	587	Syndicate Sales Corporation	L12, 280, 1295	Valley Mortgage, Inc.	C501
Simonson Lumber & Hardware	1130	T & S Custom Homes, Inc.	305	Waterfront Kitchen & Bath	295
Sisters with Jewels	L90	Tailored Living / Premier Garage	360	Watkins Products	C135
Site On Sound, Inc.	1255	Tastefully Simple	C124	Wellness Solutions	C346
Sleep Number by Select Comfort	342	TCL Insurance	C475	Western Products	C390, 545, 550
Smart Spaces	500	Terry Egan Consulting LLC	385	Western State Bank	C170
SmartRooms of North Dakota	1015	The Foam Doctor's	1193	Windows Plus, Inc.	710
Solutions	189	Thermo-Tech Windows	670	Xcel Energy	855
Stahl Architects & Builders	130	Tomahawk Log & Country Homes, Inc.	870	Your Home Improvement Co.	190
Starion Financial	260	Touch of Orange	C385		

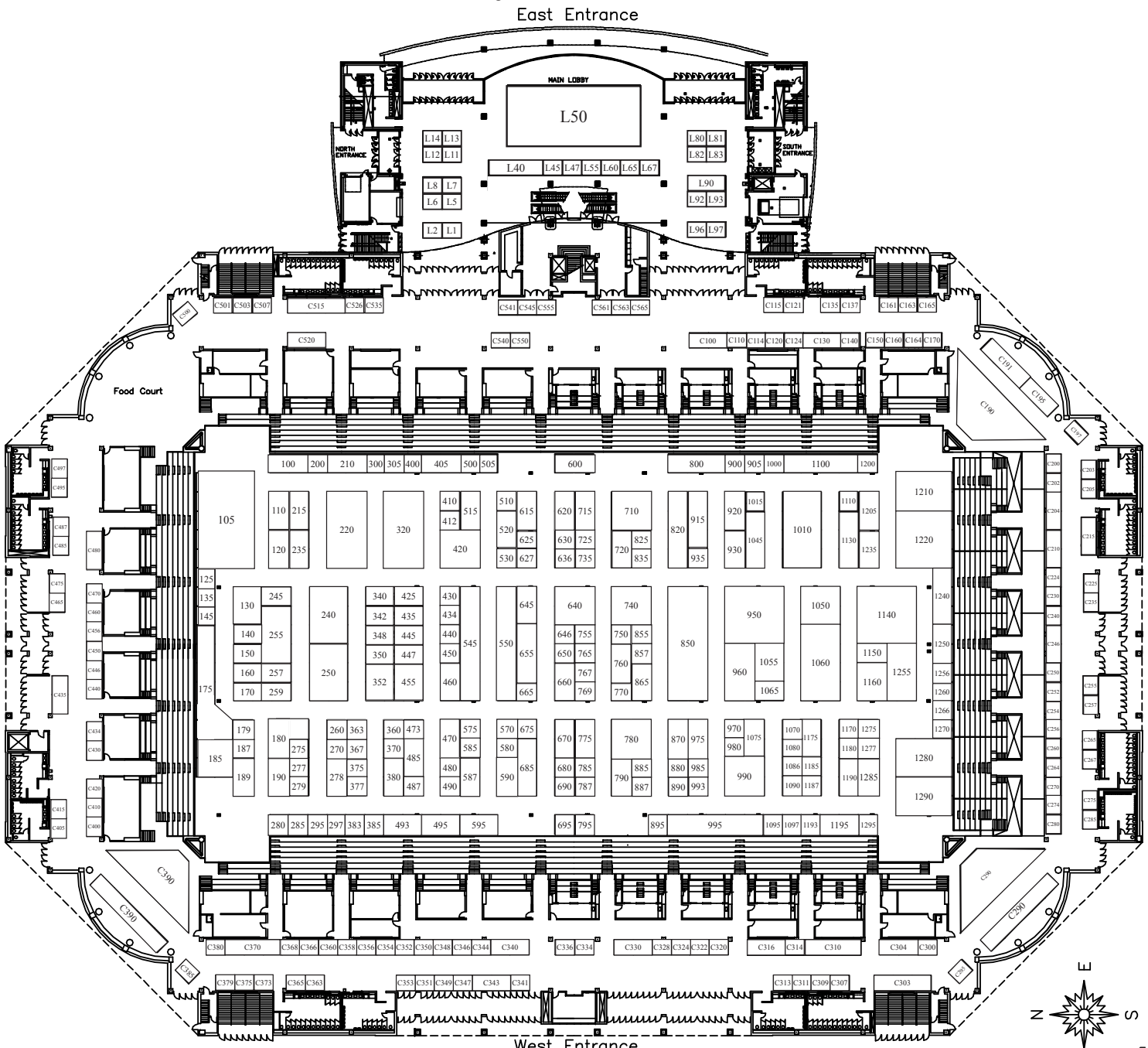

2012 Buyer's Guide

(As of Jan. 9, 2012)

This list will be published in The Forum's Home & Garden Show Guide.

Please check your company name, phone number and category.

Fax changes to (701) 280-1108, call (701) 232-5846 or email alison@hbafm.com.

Air Duct Cleaning

Hillsboro EDC	(701)636-2657
Home Heating & Plumbing	(701)280-3400
Laney's Inc.....	(701)237-0543
Steamatic of the Red River Valley	(701)232-4707

Antennas

Antenna Logic.....	(218)329-9660
--------------------	---------------

Appliances

Ferguson Bath Kitchen and Lighting Showroom.....	(701)433-7600
Nodak Stores.....	(701)293-1155
Rigels Inc.....	(218)233-6104

Architects

Building Concepts Inc.....	(701)280-2091
Chris Hawley, Architect.....	(701)367-4523
Harmonious Architecture.....	(218)251-0081
Stahl Architects & Builders	(701)241-9083

Art/Framing

Cry of the Loon Gallery	(218)330-6141
-------------------------------	---------------

Audio/Video Products

A Sound Environment.....	(701)235-6906
Arctic Audio Inc.....	(701)298-2998
Midnight Solutions Technologies	(701)347-5252
Pacific Sound and Video.....	(701)281-7246
Site On Sound Inc.....	(701)280-2272

Awnings/Canopies

Olson Awning & Canvas	(218)233-4411
-----------------------------	---------------

Basements

Basement Technologies of North Dakota, Inc.....	(701)729-0022
Drain Services, Inc.....	(701)799-8787
Innovative Basement Systems	(701)365-0097
Precision Concrete Cutters Inc.....	(701)280-7038
Studs to Rugs Inc	(701)730-0091

Bathrooms/Fixtures

Accent Kitchen & Bath.....	(701)293-6000
Braaten Cabinets Inc.....	(701)232-3109
Dakota Kitchen & Bath	(605)359-2438
Encore Home Improvements.....	(701)281-4779
Fabricators Supply.....	(701)298-0644
Facelift Kitchen and Bath.....	(701)426-0560
Ferguson Bath, Kitchen and Lighting Showroom	(701)433-7600
Lakes Specialty Services.....	(218)850-9141
Luxury Bath of Fargo	(701)356-5090
Quality Cabinets, Inc.....	(701)297-9717
Red River Glazing, Inc.....	(701)232-4717
Sculpture by Design	(218)232-0372
Waterfront Kitchen & Bath	(701)775-3911
Western Products.....	(701)280-5882
Your Home Improvement Co.....	(218)233-1822

Brick/Stone Masonry

Amcon Block & Precast	(320)251-6030
Hebron Brick Supply.....	(701)232-0781
Innovative Stone Design, LLC	(701)238-8983
Structural Materials, Inc.....	(701)282-7100
Swenson Masonry, LLC.....	(701)238-2758

Building Materials/Supplies

Blue Ox Timber Frames, Ltd.....	(320)763-9003
Crane Johnson Lumber	(701)235-3131

Dakota Wall Systems Inc.....	(701)232-5221
The Foam Doctor's	(701)526-1100
Hebron Brick Supply.....	(701)232-0781
Home Depot	(701)282-2078
Lampert Yards, Inc.....	(701)492-0292
Simonson Lumber & Hardware	(701)232-3281
Structural Materials, Inc.....	(701)282-7100

Cabinets

Accent Kitchen & Bath.....	(701)293-6000
Braaten Cabinets Inc.....	(701)232-3109
D & M Industries.....	(218)287-3100
Dakota Kitchen & Bath	(605)359-2438
Fabricators Supply.....	(701)298-0644
Facelift Kitchen and Bath.....	(701)426-0560
Granite Transformations	(605)310-2108
Home Depot	(701)282-2078
Kitchen Solvers of Fargo	(701)232-6185
Luxury Bath of Fargo	(701)356-5090
Mill Creek Custom Cabinetry.....	(218)284-0400
Quality Cabinets, Inc.....	(701)297-9717
Rusco Window Co.....	(701)281-1848
Simonson Lumber & Hardware	(701)232-3281
Tailored Living – Premiere Garage.....	(701)281-0558
Western Products.....	(701)280-5882

Closets

D & M Industries.....	(218)287-3100
Smart Spaces, Inc.....	(701)200-8770
Tailored Living – Premiere Garage.....	(701)281-0558

Coatings

Coatings Unlimited	(218)737-0037
--------------------------	---------------

Concrete

Curb Design.....	(701)866-8325
Hebron Brick Supply.....	(701)232-0781
Midwest Grinding Inc.....	(605)520-0607
Opp Construction – Patio World	(701)281-1212
Prairie Supply, Inc.....	(701)282-5656
Quality Concrete, Inc.....	(701)232-2418
Sculpture by Design	(218)232-0372
Structural Materials, Inc.....	(701)282-7100

Concrete Cutting

Precision Concrete Cutters Inc.....	(701)280-7038
-------------------------------------	---------------

Countertops

Braaten Cabinets Inc.....	(701)232-3109
CAMBRIA	(952)944-1676
Fabricators Unlimited.....	(701)235-1185
Granite Transformations	(605)310-2108
Mill Creek Custom Cabinetry.....	(218)284-0400
Quality Cabinets, Inc.....	(701)297-9717
Sculpture by Design	(218)232-0372
Stone Countertop Outlet.....	(701)200-2197
Structural Materials, Inc.....	(701)282-7100

Decks/Patios

American Custom Decks	(218)979-1483
Curb Design.....	(701)866-8325
DECKMASTERS	(701)232-4001
FM Home & Patio	(701)277-7295
Hebron Brick Supply.....	(701)232-0781
Opp Construction – Patio World	(701)281-1212
Premium Decks	(701)492-8080
Your Home Improvement Co.....	(218)233-1822

Buyer's Guide con't on next page

Buyer's Guide con't from previous page

Design/Builder

B-Dirt Construction, LLC	(218)820-5736
BFJ Home Builders, Inc.	(701)729-6401
Building Concepts Inc.	(701)280-2091
Chris Hawley, Architect	(701)367-4523
Design One Homes LLC	(701)293-5077
Foltz Buildings	(218)847-3281
Heritage Homes	(701)281-7184
HighPoint Homes	(320)763-5859
Jordahl Custom Homes, Inc.	(701)234-0404
JR Construction	(701)541-1282
Kochmann Brothers Homes, Inc.	(701)235-2525
Lakeland Log & TimberFrame Homes, Inc	(320)491-2240
Morton Buildings	(218)233-1500
Nor-Son, Inc.	(218)828-1722
Opp Construction – Patio World	(701)281-1212
Paula Rae Homes	(701)492-7410
Stahl Architects & Builders	(701)241-9083
Tomahawk Log & Country Homes	(800)544-0636

Doors/Accessories/Hardware

Comfort World Windows	(701)492-8843
Crane Johnson Lumber	(701)235-3131
D & M Industries	(218)287-3100
Fargo Glass & Paint Co.	(701)235-4441
Home Depot	(701)282-2078
Knoke Seamless Siding and Gutters	(701)361-8873
Lampert Yards, Inc.	(701)492-0292
Marvin Windows and Doors	(866)687-8441
Minnkota Windows	(701)282-7025
Nelson Window Co	(701)235-9097
Pella Windows & Doors	(701)281-1390
Simonson Lumber & Hardware	(701)232-3281
Thermo-Tech Windows	(320)980-5281
Windows Plus Inc.	(701)237-4000

Driveways/Concrete

All Finish Concrete	(701)866-2614
Curb Design	(701)866-8325
Opp Construction – Patio World	(701)281-1212

Education

Cass County Soil Conservation District	(701)282-2157
City of Fargo – Forestry Department	(701)461-8496
City of Fargo - Recycling Services	(701)298-6944
Lake Agassiz Habitat for Humanity	(218)284-5253
M State (Minnesota State Community & Technical College)	(218)299-6583
Minnesota Dept. of Health	(651)201-4619
North Dakota One Call	(701)475-2942

Electrical

Grace Electric	(701)371-3931
Laney's Inc.	(701)237-0543
Precision Plumbing, Electric, Heating & Cooling	(701)238-1753

Energy

Cass County Electric Cooperative	(701)356-4400
Enercept	(605)882-2222
Extreme Panel Technologies, Inc.	(800)977-2635
Reliable Energy Solutions, Inc.	(763)286-0817
Xcel Energy	(701)241-8633

Fencing

Dakota Fence	(701)237-6181
DECKMASTERS	(701)232-4001
DogWatch Hidden Fence – Elite Outdoor Lighting	(701)277-4949
Invisible Fence of Fargo	(218)287-1883
NEWMAN Fence	(701)235-0605

Financial Services

American Federal Bank	(218)233-2791
Bremer Bank	(701)492-2600
Edward Jones Investments	(218)287-3728
Executive Mortgage	(701)239-0155
First Class Mortgage	(701)356-9898
First International Bank & Trust	(701)277-8558

First Mortgage Service	(701)239-2671
Gate City Bank	(701)293-2456
Starion Financial	(701)281-5627
State Bank & Trust	(701)298-1562
Town & Country Credit Union	(701)356-1720
U.S. Bank	(701)280-3500
Valley Mortgage, Inc.	(701)461-8450
Western State Bank	(701)277-5003

Fireplaces

Hebron Brick Supply	(701)232-0781
Home & Hearth	(701)893-9300
Laney's Inc.	(701)237-0543
Sculpture by Design	(218)232-0372
Western Products	(701)280-5882

Flooring

Accent Kitchen & Bath	(701)293-6000
Anderson Hardwood Floors, LLC	(701)239-6079
Carpet Mill Club	(701)293-8738
Coatings Unlimited	(218)737-0037
Home Depot	(701)282-2078
Kensoks Hardwood Floors, Inc.	(701)282-6662
Lumber Liquidators	(757)566-7493
Ron Holstrom Antique Floors & More	(218)205-0194
Solutions	(701)281-2570

Furniture

Minnesota Warehouse Furniture & Amish Gifts	(218)842-5465
Ron Holstrom Antique Floors & More	(218)205-0194
Ryan's Rustic Railings & Furniture, Inc.	(218)757-3329

Garages/Door/Openers/Storage

EZ Open Garage Door, Inc.	(701)235-2802
Monkey Bars Garage Storage	(701)484-1911
Overhead Door Co. of Fargo	(701)235-3678
Tailored Living – Premiere Garage	(701)281-0558
Twin City Garage Door	(701)281-4759

Geothermal Heating & Cooling Systems

Earthloop of Fosston	(218)230-5533
Home Geothermal Systems	(701)356-6900
Lake Region Electric Cooperative	(218)863-1171
North Central Geothermal	(507)334-4436

Gutters

ABC Seamless	(701)293-5952
D & M Roofing Co.	(701)237-6494
Gutter Topper of ND, Inc.	(701)654-7694
Knoke Seamless Siding and Gutters	(701)361-8873
Lemke Home Improvements, Inc.	(218)287-0240
Western Products	(701)280-5882

Heating/Cooling Equipment/Plumbing

Custom Aire's One Hour Heating & Air Conditioning	(701)365-0365
Drain Services, Inc.	(701)799-8787
Ferguson Bath Kitchen and Lighting Showroom	(701)433-7600
Home Heating & Plumbing	(701)280-3400
Laney's Inc.	(701)237-0543
Precision Plumbing, Electric, Heating & Cooling	(701)238-1753
Reliable Energy Solutions, Inc.	(763)286-0817
Robert Gibb & Sons	(701)282-5900
Smart Rooms of North Dakota	(701)364-9276
Waterfront Kitchen & Bath	(701)775-3911

Home Products

Cutco Cutlery	(716)790-7181
Digital Media Plus, Inc.	(952)452-6428
DogWatch Hidden Fence – Elite Outdoor Lighting	(701)277-4949
Exclusive Home Products, LLC	(218)233-8888
Flags West - Pink Ink	(800)769-3524
Hazelwood Flagpoles	(218)736-4382
Royal Prestige	(816)366-0010
Home Depot	(701)282-2078
My Pillow, Inc.	(952)442-6199
Norwex Enviro Products	(218)238-6622

Buyer's Guide con't from previous page

Olson Awning & Canvas	(218)233-4411
Partylite Gifts	(701)540-1189
Real Deals on Home Décor	(701)371-5948
Ryan's Rustic Railings & Furniture, Inc.	(218)757-3329
Sanford Health Care Accessories	(701)293-8211
Shaklee.....	(218)234-1015
Sleep Number by Select Comfort	(701)281-9666
Sun Companies.....	(701)297-6990
Syndicate Sales Corporation.....	(952)932-2993
Watkins Products.....	(800)449-9446

Home Repair

Accent Kitchen & Bath.....	(701)293-6000
Price-Rite Home Imp., Inc.....	(701)277-1692

Home Services

Accent Kitchen & Bath.....	(701)293-6000
Dust Busters Furnance & Duct Cng., Inc.....	(320)763-6658
Merry Maids.....	(701)799-0244
Paul Bunyan Tree Service.....	(701)238-9888
Steam Masters Carpet Care.....	(701)232-6060
Steamatic of the Red River Valley	(701)232-4707
Superior Steam Cleaning & Restoration.....	(701)282-4159
Valley Central Vacuum.....	(701)205-9225

Homes

Anderson Homes, Inc.....	(218)837-5177
Barnesville Homes Inc.....	(218)354-7757
B-Dirt Construction, LLC.....	(218)820-5736
BFJ Home Builders, Inc.....	(701)729-6401
Building Concepts Inc.....	(701)280-2091
Design One Homes LLC.....	(701)293-5077
Edgewood Village.....	(701)388-2222
Heritage Homes.....	(701)281-7184
HighPoint Homes.....	(320)763-5859
Homark Homes Inc.....	(218)253-2777
Jordahl Custom Homes, Inc.....	(701)234-0404
JR Construction.....	(701)541-1282
Kochmann Brothers Homes Inc.....	(701)235-2525
Lake Agassiz Habitat for Humanity.....	(218)284-5253
Lakeland Log & Timberframe	(320)491-2240
Nor-Son, Inc.....	(218)828-1722
Northwoods Log Homes Inc.....	(218)224-2251
Paula Rae Homes	(701)492-7410
T & S Custom Homes, Inc.....	(701)793-3022
Tomahawk Log & Country Homes.....	(800)544-0636

Insulation

Enercept	(605)882-2222
Extreme Panel Tech., Inc.....	(800)977-2635
The Foam Doctor's	(701)526-1100
InSealation Solutions, LLC	(701)238-6269
Interstate Spray Foam	(701)492-6208
Your Home Improvement Co.....	(218)233-1822

Insurance

American Family Insurance	(701)280-1100
Great Plains Brokerage – Sanford Health Plan	(605)328-7000
TCl Insurance.....	(701)799-8585

Interior Decorating & Design

Accent Kitchen & Bath.....	(701)293-6000
Design Direction	(701)365-4040
Design One Homes LLC.....	(701)293-5077
Interior Affairs	(218)233-0783
Rose Creek Design	(701)893-5134

Kitchens

Accent Kitchen & Bath.....	(701)293-6000
Braaten Cabinets Inc.....	(701)232-3109
D & M Industries.....	(218)287-3100
Encore Home Improvements.....	(701)281-4779
Dakota Kitchen & Bath	(605)359-2438
Facelift Kitchen and Bath.....	(701)426-0560
Kitchen Solvers of Fargo	(701)232-6185
Quality Cabinets, Inc.....	(701)297-9717

Waterfront Kitchen & Bath	(701)775-3911
Western Products.....	(701)280-5882
Your Home Improvement Co.....	(218)233-1822

Landscaping/Gardening

A & T Landscaping	(218)303-0208
Absolute Landscaping LLC.....	(701)388-8937
Baker Garden & Gift	(701)237-6255
Bergeson Nursery	(218)945-6988
Curb Design.....	(701)866-8325
Curb-Xtrehm	(218)732-4128
Greenscape Companies, Inc.....	(701)325-0363
Hebron Brick Supply.....	(701)232-0781
Oasis Plantscapes.....	(701)361-2401
Opp Construction – Patio World	(701)281-1212
Signature Landscapes.....	(701)281-1208
Prairie Restorations, Inc.....	(218)498-0260

Lawn/Garden Equipment

Fargo Tractor.....	(701)282-5290
Home Depot	(701)282-2078
Nodak Stores.....	(701)293-1155
Northern Turf Management, Inc.....	(701)293-4085

Lighting

Ferguson Bath Kitchen and Lighting Showroom	(701)541-0830
Home Depot	(701)282-2078
Reliable Energy Solutions, Inc.....	(763)286-0817
Valley Lights	(701)277-0344

Magazines/Newspapers

New Century Press.....	(218)287-1288
Outdoor Design & Living Guide.....	(701)282-0619

Other

DIY Wood Studio	(701)293-1310
Energy Balance Systems	(763)350-4200
Fargo Imports	(701)361-1698
Great Plains Brokerage – Sanford Health Plan	(605)328-7000
Healing Arts Chiropractict.....	(701)451-9070
In the Shades	(701)200-9201
JD's Salsa in Seconds.....	(952)200-9877
Life Chiropractic Center	(218)233-3600
M & E Sales.....	(715)379-1020
Mark Enterprises, Inc.....	(952)544-6175
Mini ISmart Massager	(763)350-4200
My Pillow, Inc.....	(952)442-6199
Nectar of the Vine.....	(440)773-0103
Nichols Family Chiropractic	(701)356-3111
Official Massage Pillow.....	(701)201-0088
Partylite Gifts	(701)540-1189
Scentsy.....	(701)866-7315
Sisters with Jewels	(605)695-3369
Tastefully Simple.....	(701)261-1837
Terry Egan Consulting, LLC	(612)386-9309
Touch of Orange.....	(218)999-5030
Wellness Solutions	(701)232-4770

Outdoor Living

Home Depot	(701)282-2078
Nodak Stores.....	(701)293-1155
Opp Construction – Patio World	(701)281-1212
Western Products.....	(701)280-5882

Paint/Painting Services

Fargo Glass & Paint Co.....	(701)235-4441
Home Depot	(701)282-2078

Real Estate/Developments

Arista Realty – Horizon Shores	(218)236-1133
Barnesville Economic Development Authority	(218)354-2145
Chase Realty.....	(701)261-3384
City of Dilworth	(218)287-2313
City of Frazee	(218)334-4991
City of Kindred	(701)428-3115
Coldwell Banker First Realty	(701)293-3423

Buyer's Guide con't from previous page

Edgewood Village	(701)365-4751
Hankinson Community Development Corporation, Incorporated	(701)242-7292
Hillsboro EDC	(701)636-2657
Jack Chivers Realty	(218)847-3112
Mayville Portland EDC	(701)636-2657
NAI North Central	(701)306-5419
Park Co. Realtors	(701)237-5031
Property Resources Group	(701)356-8888
Prudential Premier Real Estate	(701)356-3600
RE/MAX Realty 1	(701)235-5990
Town & Country Realty LLC	(701)293-3333

Recreation

Backyard Adventures	(701)235-1075
DECKMASTERS	(701)232-4001
Rainbow Play Systems	(701)373-0111
Tubs of Fun!	(701)234-0705
Western Products	(701)280-5882

Recycling

City of Fargo-Recycling Services	(701)298-6944
--	---------------

Remodeling

Accent Kitchen & Bath	(701)293-6000
Home Depot	(701)282-2078
Kochmann Brothers Homes Inc.	(701)235-2525
Price-Rite Home Imp., Inc.	(701)277-1692
Studs to Rugs, Inc	(701)730-0091
Your Home Improvement Co.	(218)233-1822

Roofing

ABC Seamless	(701)293-5952
Boulder Creek Custom Homes LLC	(605)553-3934
D & M Roofing Co.	(701)237-6494
Rusco Window & Cabinets.	(701)281-1848
Western Products	(701)280-5882
Your Home Improvement Co.	(218)233-1822

Safety

North Dakota One Call	(701)475-2942
-----------------------------	---------------

Saunas/Spas/Hot Tubs/Whirlpools

Hot Spring Spas & Pool Tables 2	(701)364-3725
Olson Pools & Spas	(218)483-3541
Tubs of Fun!	(701)234-0705
Western Products	(701)280-5882

Security

A Sound Environment	(701)235-6906
Electro Watchman, Inc.	(701)235-9511
Sensible Security	(701)478-7233
Security Solutions Powered by ACS	(218)346-5500

Siding

ABC Seamless	(701)293-5952
Boulder Creek Custom Homes LLC	(605)553-3934
Comfort World Windows	(701)492-8843
D & M Roofing Co.	(701)237-6494
Encore Home Improvements	(701)281-4779
Hanlon Construction	(701)277-1171
Home Depot	(701)282-2078
Knoke Seamless Siding and Gutters	(701)361-8873
Lemke Home Improvements, Inc.	(218)287-0240
Price-Rite Home Imp., Inc.	(701)277-1692
Rusco Window & Cabinets.	(701)281-1848
Simonson Lumber & Hardware	(701)232-3281
Western Products	(701)280-5882
Your Home Improvement Co.	(218)233-1822

Stained Glass

Turtle Shell Stained Glass Studio	(701)371-1644
---	---------------

Sunrooms

Western Products	(701)280-5882
------------------------	---------------

Swimming Pools/Accessories

Olson Pools & Spas	(218)483-3541
Tubs of Fun!	(701)234-0705

Tools

ACME TOOLS	(701)476-4602
Midwest Fasteners	(701)364-9088
Twin City Sharpening, Inc.	(701)237-5344

Trusses

Crane Johnson Lumber	(701)235-3131
Northland Truss Systems, Inc.	(701)282-4477

Water Treatment/Purification

Bernie's Water Conditioning	(218)233-4751
Culligan Water Conditioning	(701)232-7878
Environmental Air Solutions, Inc.	(701)478-7877
FM Water Systems, LLC – Kinetic	(701)232-5664
High Plains Water.	(701)840-8135
Laneys Inc.	(701)237-0543
Lindsay Ecowater Systems	(218)233-8655

Window Coverings

Budget Blinds of Fargo	(701)237-6141
Design Direction, Inc.	(701)365-4040
Design One Homes	(701)293-5077
Rose Creek Design	(701)893-5134
Solutions	(701)281-2570

Windows

ABC Seamless	(701)293-5952
Boulder Creek Custom Homes LLC	(605)553-3934
Comfort World Windows	(701)492-8843
Crane Johnson Lumber	(701)235-3131
D & M Industries	(218)287-3100
Encore Home Improvements	(701)281-4779
Fargo Glass & Paint Co.	(701)235-4441
Hanlon Construction	(701)277-1171
Home Depot	(701)282-2078
JR Construction	(701)541-1282
Knoke Seamless Siding and Gutters	(701)361-8873
Lampert Yards, Inc.	(701)492-0292
Marvin Windows and Doors	(866)687-8441
Minnkota Windows	(701)282-7025
Nelson Window Co	(701)235-9097
Pella Windows & Doors	(701)281-1390
Prairie Windows	(701)361-7610
Precision Concrete Cutters Inc.	(701)280-7038
Price-Rite Home Imp., Inc.	(701)277-1692
Rusco Window & Cabinets.	(701)281-1848
Simonson Lumber & Hardware	(701)232-3281
Thermo-Tech Windows	(320)980-5281
Turtle Shell Stained Glass	(701)371-1644
Western Products	(701)280-5882
Windows Plus Inc.	(701)237-4000
Your Home Improvement Co.	(218)233-1822

NEW

2-For-1 Admission Hours:

3 - 5 p.m. Friday, Feb. 24

9 - 11 a.m. Saturday, Feb. 25

3 - 5 p.m. Sunday, Feb. 26



Red River Valley HOME & GARDEN SHOW

www.hbafm.com

2012 Program

February 24-26, 2012

SPACE & COPY DEADLINE

Friday, January 20, 2012

FULL COLOR, GLOSSY MAGAZINE WILL BE DELIVERED IN THE FORUM

Sunday, February 19, 2012

Distributed at the show and at all Hornbacher's locations.

The Forum reaches over 115,000 readers every Sunday. Target your advertising dollar to the ideal market you are trying to reach!
*ABC Audit 2010



<p>Full Page with bleed 8.75 x 11.25 Live text area 7.75 x 10.25</p> <p>\$2,580</p>	<p>1/2 Page (H) 7.31 x 4.94 (V) 3.56 x 10</p> <p>\$1,390</p>	<p>1/4 Page 3.56 x 4.91</p> <p>\$799</p>	<p>1/8 Page 3.56 x 2.38</p> <p>\$435</p>	<p>1/12 Page 2.38 x 2.38</p> <p>\$280</p>
---	---	---	---	--

Premiere Position: Back Page with Full Color \$2825

The Forum
of Fargo-Moorhead

Contact your Forum Consultant or call 241-5496 for more information.

Seminar Schedule & Descriptions

Main Stage Programs

- Friday, February 24**.....**Show Hours: 3 – 9 p.m.**
 4:30 – 5:30 p.m. “Behind the Scenes: Secrets from HGTV’s Curb Appeal: The Block,” John Gidding
 6:30 – 7:30 p.m. “Tips for Improving Your Home’s Curb Appeal,” John Gidding
- Saturday, February 25****Show Hours: 9 a.m. – 6 p.m.**
 9:30 – 11 a.m..... “Any Size, Anywhere Edible Gardens Part 1: Growing Tips & Techniques,” William Moss
 Noon – 1 p.m..... “Behind the Scenes: Secrets from HGTV’s Curb Appeal: The Block,” John Gidding
 2 – 3 p.m. “Tips for Improving Your Home’s Curb Appeal,” John Gidding
 4 – 5:30 p.m. “Best Container Plants for Food & Flowers Part 1: Growing Tips & Techniques,” William Moss
- Sunday, February 26**..... **Show Hours: 11 a.m. – 5 p.m.**
 11:30 a.m. – 1 p.m..... “Best Container Plans for Food & Flowers Part 2: Choosing Best Performing Plants,” William Moss
 2 – 3:30 p.m. “Any Size, Anywhere Edible Gardens Part 2: Selecting Best Plant Varieties,” William Moss

Mezzanine Level Programs

- Saturday, February 25****Show Hours: 9 a.m. – 6 p.m.**
 10 a.m. – 5 p.m..... Kids Workshop – sponsored by The Home Depot
 11 a.m. – Noon..... “Bathroom Trends for 2012,” Tom Spaeth & Kayla Benning, Accent Kitchen & Bath
 3 – 4 p.m. “Kitchen Trends for 2012,” Mike Arnold & Kayla Benning, Accent Kitchen & Bath
- Sunday, February 26**..... **Show Hours: 11 a.m. – 5 p.m.**
 Noon – 4 p.m..... Kids Workshop – sponsored by The Home Depot
 1 – 2 p.m. “Bathroom Trends for 2012,” Tom Spaeth & Kayla Benning, Accent Kitchen & Bath
 3:30 – 4:30 p.m. “Kitchen Trends for 2012,” Mike Arnold & Kayla Benning, Accent Kitchen & Bath

Seminar Descriptions

John Gidding

Behind the Scenes Secrets from HGTV’s Curb Appeal: The Block

John Gidding, host and designer from HGTV’s popular series Curb Appeal: The Block, will share behind the scenes dish from fan favorite projects - from hidden obstacles, to money-saving tips and more.

Tips for Improving Your Home’s Curb Appeal

For three seasons, John Gidding has been guiding homeowners through projects that instantly increase curb appeal, and now he’s sharing tried-and-true tricks and tips with guests of the show.

William Moss

Any Size, Anywhere Edible Gardens

Bring the taste of homegrown freshness to your gardening experience. **Part 1:** Join William Moss as he shares tips and techniques for growing nutritious fruits and veggies for you and your family. **Part 2:** Learn how to select the best plants and varieties for your area.

Best Container Plants for Food & Flowers

With proper plant selection and care, container gardens can provide both nutrition and ornament. **Part 1:** Moss will show tried-and-true techniques for success growing in containers. **Part 2:** Learn which plants perform best in containers.

Accent Kitchen & Bath

Bathroom Trends for 2012

2012 will be a banner year for new, exciting products. Learn about today’s new barrier-free shower systems that look great and allow “aging in place” for the older population. Learn about endless ways to incorporate tile throughout the bathroom. This is a must-see seminar for anyone who is planning a new bathroom.

Kitchen Trends for 2012

Accent will walk you through the latest products of 2012 for the kitchen. This includes appliances, cabinet layout, flooring, countertops, lighting, plumbing and more. This is perfect for the do-it-yourselfer, the remodeling contractor and new home builders. Everything is covered from products, to installation, to budgeting.

Market your company the right way!

Tips for before, during and after the show

Before the Show:

A major trade show requires considerable advance preparation and, if you aren't ready, can present a logistical nightmare. You must develop a solid plan and monitor your progress vigilantly.

1. **Evaluate and select trade shows carefully:** Participating in a show can require a major investment of time, money and resources. Be tough in your evaluation of a show's worthiness. Are the attendees likely customers for your organization? Exposure to a few hundred very qualified targets is better than exposure to thousands of generalists who are very unlikely to be interested in your business. The HBA has gotten extremely positive feedback from most exhibitors that this is a very profitable experience with promising leads.
2. **Read the enclosed Exhibitor Packet materials:** Before you do anything, read the enclosed information and the information on your show contract. This should have everything you need including a floor plan with your **new booth number** and other exhibitor specifications. If you are using your booth number in any advertising, make sure it is the NEW booth number. You will receive your FINAL exhibitor packet in February.
3. **Identify your goals:** Be specific about the things you want to accomplish as a result of your participation in the show. Do you want to increase visibility, gain exposure to a large number of customers who might be interested in your products or check out the competition? Concrete goals are important to determine the value of the trade show to your organization.
4. **Define measurements of success:** For each goal, determine a way to measure its success. Make these measurements as specific as possible. You could plan to hand out 1,000 brochures, obtain contact information for at least 200 prospects, or take a key client out to lunch. These benchmarks will help you decide whether the show was worth the expense.
5. **Put your show plan in writing:** The plan should include a workable schedule, a comprehensive list of preparation activities, and an individual assigned for each task. You cannot leave things to chance, or else Murphy's Law (whatever can go wrong, will go wrong) will surely prevail!
6. **Develop a key message for your booth exhibit:** Like good advertising, a good exhibit clearly communicates one major message. This draws more prospects to your booth than an unfocused multitude of messages.
7. **Design an open, inviting booth:** An open booth design, with no tables obstructing access, invites attendees to come in. Your logo should be big enough to be seen from a good distance. Maximize "walking around" space by mounting brochure displays on walls. Use interesting graphics to draw people's attention. For demos, laptops and flat-screen monitors are space-efficient. If space permits, provide comfortable chairs to encourage prospects to linger. A portable booth should be reasonably easy to set up and take down. The six key elements of a display booth are graphics, color, lighting, literature, booth layout and location.
8. **Advertise your show participation:** Use tag lines such as: "see us at Booth 15 at the Red River Valley Home & Garden Show" in news releases and other communications leading up to the show (even if those releases are about something unrelated). Write a news release announcing show-related news. Invite clients to stop by the booth, or set up appointments between them and your spokespeople. Be sure to tag any advertising you are running and to list your show booth number and dates on your company website.
9. **Order all necessary supplies, including brochures and giveaways:** If your marketing collateral needs to be updated or redesigned, take care of this early. You don't want to run the risk of having no brochures to hand out. Design forms for easily capturing prospect information—clear forms eliminate guesswork. Consider giveaways to generate attention and a sense of fun. These don't have to be expensive. Pens, grocery bags or other items with your web address and a catchy slogan can be very effective.
10. **Design PowerPoint presentations and demos for the booth:** These will draw attendees to your booth and help them learn more about your business. Presentations will allow you to communicate information to many prospects at once.
11. **Create a unique identity for your booth staff:** Decide on the dress code for your staff. Matching blazers, T-shirts or even boutonnieres will make your representatives easily identifiable.

Tips con't from previous page

- 12. Train your exhibit staff before each show:** This is very important! Your staff needs to know what is expected of them. They need to be briefed on all new programs and initiatives that should be emphasized. They must know how to run the demos and presentations, and they should know some basic trouble shooting. Nothing looks more unprofessional then demos that don't work.

During the Show:

1. **Set up a rotating booth schedule for your staff:** Your staff needs breaks for lunch and relaxing. They will be more cheerful if they don't have stay at the booth all day long. General manpower requirements are two people for every 80 sq. ft. The reason why staffing requirements are so critical is based on consumer behavior at shows. Studies show that of all the people who might stop and talk with you at your booth, 20 percent of the people will not wait to talk to a company representative if they are busy, 15 percent will only wait 30 seconds, 40 percent will wait 1 minute and 25 percent will wait 3 minutes. What's the consumer's reasoning behind this? The consumer who might have an interest in your product has a few options. First, a consumer will come back around and talk when the exhibitor is not busy which might not happen. Second, there might be some similar products in the other aisles. Third, the consumer may want to do a quick walk through and then come back. In many cases, after the time it takes to do a walk-through and talk to a couple of exhibitors, the consumer may be too tired and goes home. Fourth, the consumer will come back tomorrow.
2. **Remind staff to record all prospect information:** Encourage your staff to record everything they can learn about a prospect's needs and experience with your company. Stress the importance of getting phone numbers and email addresses.
3. **Encourage staff to greet people warmly and smile:** Amazingly, this is often forgotten. An inviting attitude can give a valuable first impression. The staff should avoid having their backs to the entrance, or taking phone calls while on duty. A friendly greeting to passersby may encourage them to stop rather than simply walk by. Staff who is uniformly courteous, helpful, knowledgeable about all aspects of the industry and responsive to requests will make a very good impression.

After the Show:

1. **Send requested literature immediately:** Send requested material within 24 hours. A quick response is your second opportunity to make a favorable impression. (Your performance in the booth is the first.)
2. **Include a teaser on the envelope or in the email subject line:** Be sure to mention your organization's name and the name of the show on the outside of the envelope or in the email subject line, so they know your letter is not junk mail.
3. **Help your prospects take the next step:** Make sure your literature packages make responding easy for prospects by including your web address and information on the opportunities available to them.
4. **Keep track of your prospects:** Nothing signals the success of your trade-show effort better than having prospects purchase your products or having the media spotlight your efforts. Keep a record of the customers who found out about your products through the trade show. Use these results to demonstrate the show's return on investment.
5. **Analyze "lessons learned":** After each show, evaluate what went well and what didn't. Critique each aspect of the show and ask others for comments. Pay special attention to feedback regarding communication to prospective customers. The 'lessons learned' will help improve your efforts in future shows.

Have fun and good luck at the Red River Valley Home & Garden Show!

Consider sponsoring the show to get thousands of dollars of additional exposure through event advertising and promotion before and during the event.

See the back cover for details!

Fargodome Fire Marshal Requirements

All booths must be in compliance with the following requirements or the whole show may be shut down!



If your exhibit contains any petroleum based products (i.e. gasoline) the following guidelines must be met:

1. The gas tanks must be less than 1/3 full of fuel.
2. The gas tanks must be taped shut.
3. The battery terminals must be disconnected.

Displaying Grills

All grill units that are displayed while “hot” in any vendor booth must be placed in the back half of the booth. Due to the large volume of people attending the show, grills are not to be permitted in the front half of any booth space.

LP Gas to Fuel Grills, Fireplaces

The Fargo Fire Marshal will not allow any LP gas tanks in the building to be larger than five pounds. Tanks may be attached to each display unit, but the tanks must be kept a minimum of 20 feet apart. Units may be turned on and off for demonstration, as long as no two or more units in use are within 20 feet of each other. Additional tanks should be stored in your vehicle/trailer.

Parking During Move-In

Do not park on the sidewalks! It blocks the doors, and because of this, it is against fire code. You may park in front of the doors only to drop off. DO NOT leave your vehicle unattended. If you are parked illegally, the FARGODOME will have your vehicle towed away.

Thank you for your cooperation!
For questions call the HBA at (701) 232-5846.

Education Opportunity 'Lunch & Learn'

'Take Your Home Show Booth / Parade Home Over the Top in 2012'

Speaker Jodee Bock from Keller Williams Roers Realty and Bock's Office will help YOU get the most from your Home & Garden Show and Parade of Homes experience. Attend this seminar to brush up on trade show basics, learn some sales techniques for that "face-to-face" environment, and discuss ways to make your product stand apart from the competition. Questions and discussion are highly encouraged.



When: 11:30 a.m. - 1 p.m. Tuesday, Jan. 24

Where: HBA of F-M office, 1802 32nd Ave. S., Fargo

Cost: \$10 (includes lunch!)

Register: Contact Kirsten at (701) 232-5846 or kirsten@hbafm.com or fill out the information below.

Please register the following person(s):

- 1) _____
- 2) _____
- 3) _____
- 4) _____
- 5) _____

Name: _____

Company: _____

Billing Address (of Credit Card if used): _____

City, State, Zip: _____

Please use my credit card (circle one): Visa/Mastercard # _____

Exp. _____ VIN (3 digits on back) _____

Return form and payment to the HBA office: 1802 32nd Ave. S., Fargo, ND 58103 | F (701) 280-1108

All registrants must be pre-paid and received at least 24 hours in advance of the class. Refunds will only be provided if notice of cancellation is received 24 hours before the class.

Sponsors & Sponsorship Opportunities



Want more exposure?

There are multiple levels of sponsorships available for both members and non-members and we want to help find the perfect one for you!

Sponsors for the Red River Valley Home & Garden Show get the chance to promote their companies through radio, television and print advertising. Don't miss out on this great opportunity to get your company in front of THOUSANDS of consumers.

Contact Jenny today for more information on sponsorship opportunities:
(701) 232-5846 or jenny@hbafm.com.



What's coming in your **FINAL PACKET:**

- 1. NAME BADGES:** If ordered and requested by Feb. 3. ONLINE FORM at www.hbafm.com/exhibitor.
- 2. WEEKEND PARKING PASS:** (value \$12) compliments of the HBA! The number of passes included will depend on size of exhibit! DO NOT LOSE THESE. THEY WILL NOT BE REPLACED. More info on parking passes on page 5.
- 3. MOVE-IN PASS(ES):** If you scheduled a move-in or drive-in time with Bryce at (701) 232-5846.
- 4. EXHIBITOR DISCOUNT TICKETS:** If ordered by Feb. 3. Available for \$6 each. (Regular ticket price is \$8.)